

Quilting With The Grace NM-EZ3™ Quilting Frame

Table Of Contents

Helpful Information.....	X
Care, Finishing And Storage.....	X
Warranty.....	X
Parts List.....	X
Assembly.....	1
Before You Begin.....	1
Step 1 Install Hardware To Diagonal Stand.....	1
Step 2 Install Hardware To Pivot Section.....	1
Step 3 Install Hardware To Mounting Ends.....	2
Step 4 Base Feet To Diagonal Stand.....	2
Step 5 Pivot Sections to Diagonal.....	2
Step 6 Ratchet Wheels to Poles.....	3
Step 7 Assembling the Frame in Different Sizes.....	3
Step 8 Ratchet Stops and Poles with Wheels to Mounting Ends	4
Step 9 Brace Assembly.....	5
Step 10 Pole/End Assembly To Leg/Stand/Pivot Assembly	5
Folding The EZ3™.....	6
Tilting The EZ3™.....	7
Quilting Instructions.....	7
Preparing The Fabric Layers For Installation.....	7
Installing The Quilt Fabrics.....	7
Trouble Shooting.....	9
Tying Quilts.....	10
Making And Using Cloth Leaders.....	10



Copyright November 2000 Jim M. Bagley
GraceWood, Inc. Reproduction Prohibited,
Patent Pending

Care of your NM-EZ3™

The frame may be sealed and/or stained with an application of tung oil which will help preserve the wood and will help to prevent warping. To add a certain color to your frame, you may use a Danish Oil finish. We recommend the Dett™ or Watco™ brands. Test stain on an inconspicuous place. Many different finishes and/or stains may be suitable for sealing and beautifying your frame. You may want to consult your local paint retailer for finishes which will apply easily and dry hard-not oily.

Tips

- Store frame in a dry place-preferably with poles and braces in vertical position if not assembled.
- Do not carry the frame by the quilting poles.
- Do not drop the frame or let it twist out of square.

Warranty

Warranty card must be filled out and sent to: **GraceWood, Inc. EZ3™ Warranty**
P. O. Box 27823
Salt Lake City, Utah 84127

GraceWood, Inc. will replace or repair, at our choosing, any part of the Grace NMEZ3™ Quilting Frame, which may be shown to be defective. Warranty expires one year after the date of purchase and does not cover parts damaged through misuse, improper storage, improper assembly, loss, natural events and willful or accidental destruction. Defective parts may be returned only with a valid RMA# or Returned Merchandise Authorization Number which may be obtained by calling GraceWood, Inc. at **(801) 485-6688**. Warranty registration card must be returned within 30 days of purchase for warranty to be valid.

For correspondence concerning your NMEZ3™, write to:

The Grace Company
P.O. Box 27823
Salt Lake City, UT 84127

For shipping of materials to the Grace Company address package (postage prepaid) to: The Grace Company, 801 West Layton Avenue, SLC, UT 84104 Materials may be returned only with a valid RMA# or Returned Merchandise Authorization Number which may be obtained by calling GraceWood, Inc. at **(801) 485-6688**.

For technical support, call (801) 485-6688. All calls will be returned. Please report any errors in these instructions or make constructive comments to the following:

FAX - (801) 485-4388 - E-mail - info@graceframe.com - <http://www.graceframe.com>

About the Grace Quilting Frame

The Grace Quilting System has been developed over the past decade with several original design innovations. Due to feedback from many of the thousands of quilters who have purchased and do use the GraceFrame™, we have been able to make a frame that will truly enhance the entire process of hand quilting from beginning to end. If you have any suggestions that will help us to improve our product or service, please write to The Grace Company.

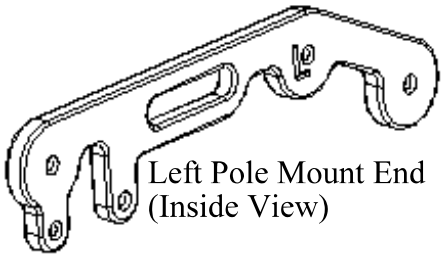

Left Pole Mount End
(Inside View)

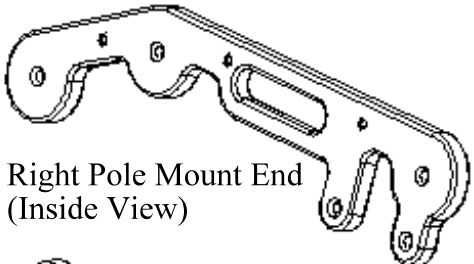

Right Pole Mount End
(Inside View)

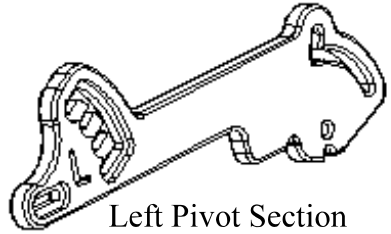

Left Pivot Section
(Inside View)

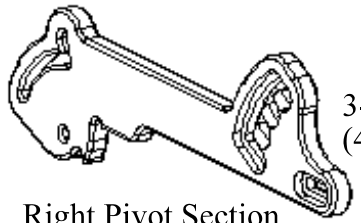

Right Pivot Section
(Inside View)



Left Base Foot
(Inside View)



Right Base Foot
(Inside View)

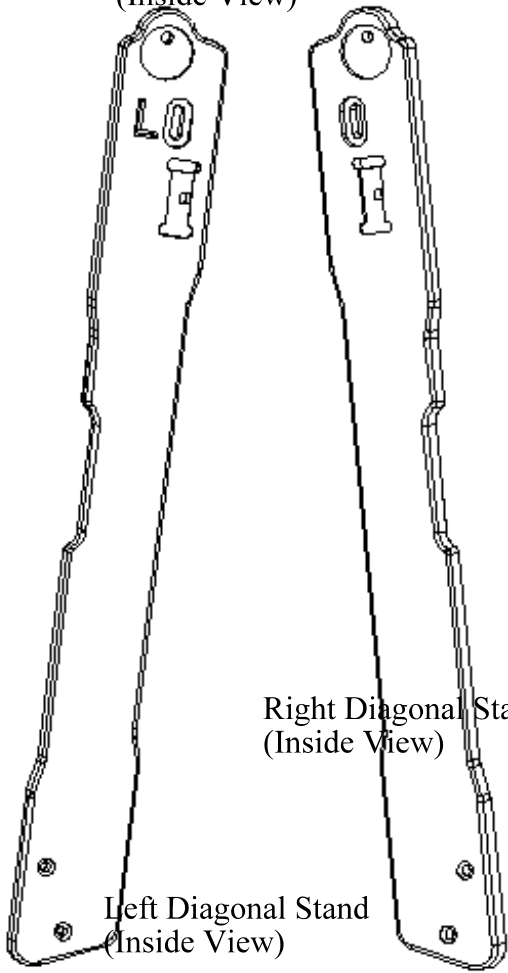

Left Diagonal Stand
(Inside View)

Right Diagonal Stand
(Inside View)

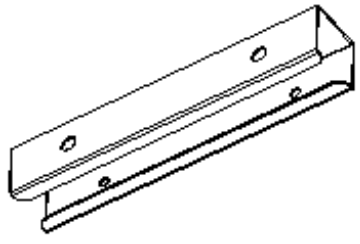

Connecting Sleeve

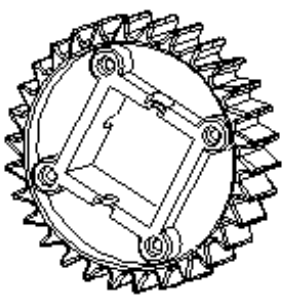

3--Cog Wheels



3--Cog Stops

3--Longer Rail
(56" crib size)

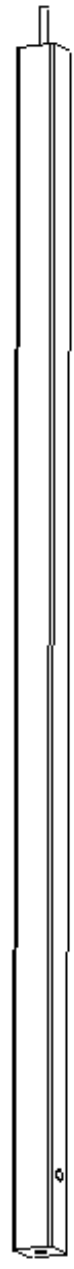

2--Brace (104")

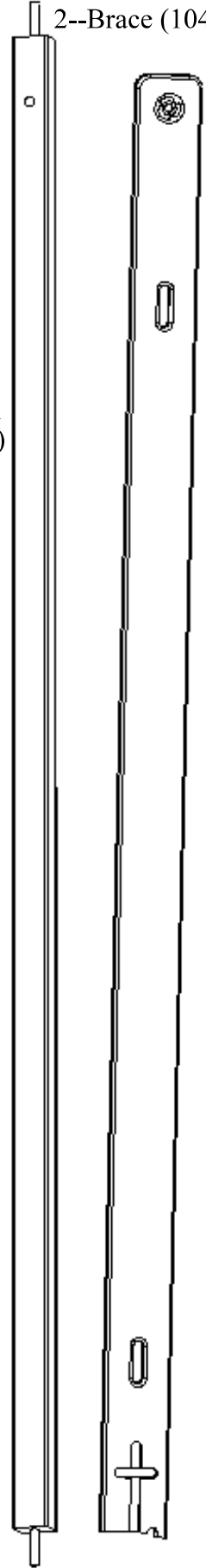

3--Shorter Rail
(40" extension)



20--1/4" Flat Washer (Smaller)



14--5/16" Flat Washer (Larger)



12--5/16" Jamb Nut (Thinner)



12--5/16" Nylon Locking Nut (Thicker)



3--1/4" x 1 1/2" Hex Head Bolt (Thinner)

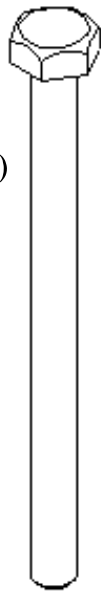

2--1/4" x 3" Hex Head Bolt

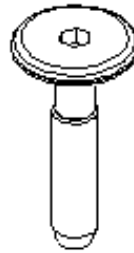

6--Connector Bolt

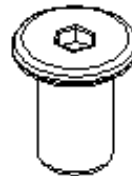

6--Cap Nut

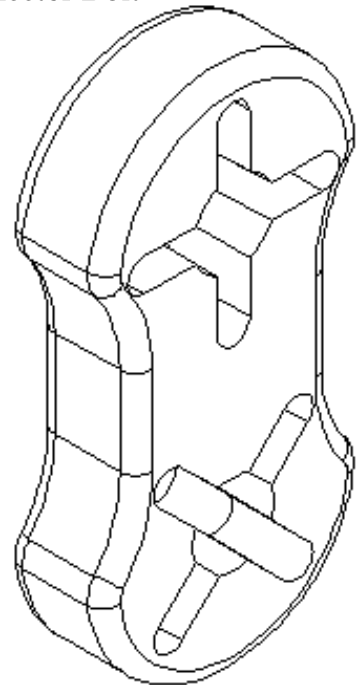

1--Wing Grip Tool

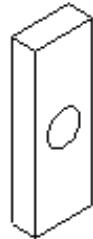

2--Rectangle Nuts

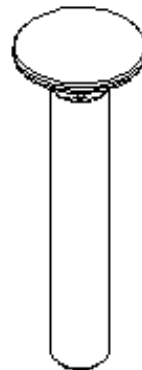

12--5/16" x 2" Carriage Bolt



6--Screw



6--5/16" Wing Nut

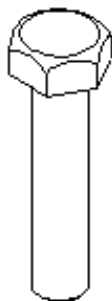

2--5/16" x 1 1/2" Hex Head Bolt (Thicker)



6--Plastic Washer

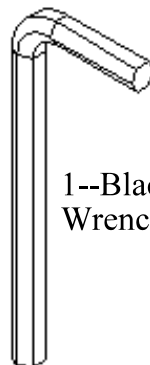

1--Black Alan Wrench (Smaller)

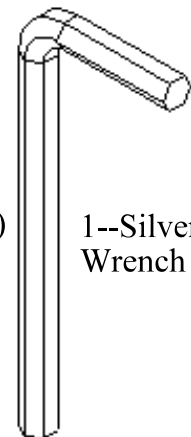

1--Silver Alan Wrench (Larger)

Quilting With the Grace NM-EZ3™ 56/96 Quilting Frame

Before You Begin

- < Using the parts list as a reference, take the parts out of the box and make sure that you have them all. (If there is something missing or broken, contact The Grace Company. We will promptly ship any needed item.)

Tools Needed

- < To assemble the frame you will need a few common tools. Once the frame is assembled, no tools will be needed for the use of the frame.
 1. One 1/2" wrench
 2. One 7/16" wrench (A combination or socket wrench will also work.)
 3. Phillips Head Screw Driver

Note: To help you distinguish wood parts, all Left Side parts are marked with an "L" grooved into the wood on the inside of the part.

Step 1: Hardware to Diagonal Stands

Parts Needed: Right and Left Diagonal Stands
6 - 5/16" x 2" Carriage Bolts
6 - Jamb Nuts
6 - 1/4" Smaller Flat Washers

- < Note direction carriage bolt goes through the part.
- < Tighten nuts on carriage bolt to pull the square part of the bolt into the wood until the bolt is seated into the wood part.

Step 2: Hardware to Pivot Sections

Parts Needed: Right and Left Pivot Sections
2 - 5/16" x 2" Carriage Bolts
2 - Jamb Nuts
2 - 1/4" Smaller Flat Washers

- < Note direction of carriage bolts to Pivot Sections. (See Below)
- < Position carriage bolts through pivot sections as shown in drawing. Tighten jamb nuts over end of carriage bolts until the square part of the carriage bolt is drawn and seated into the wood.

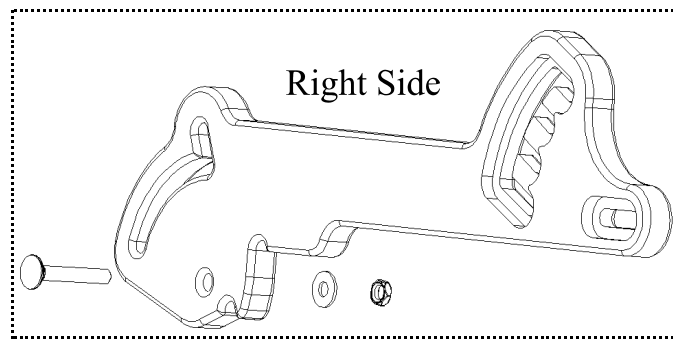
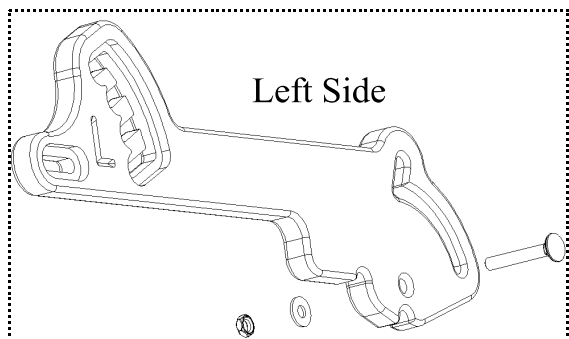
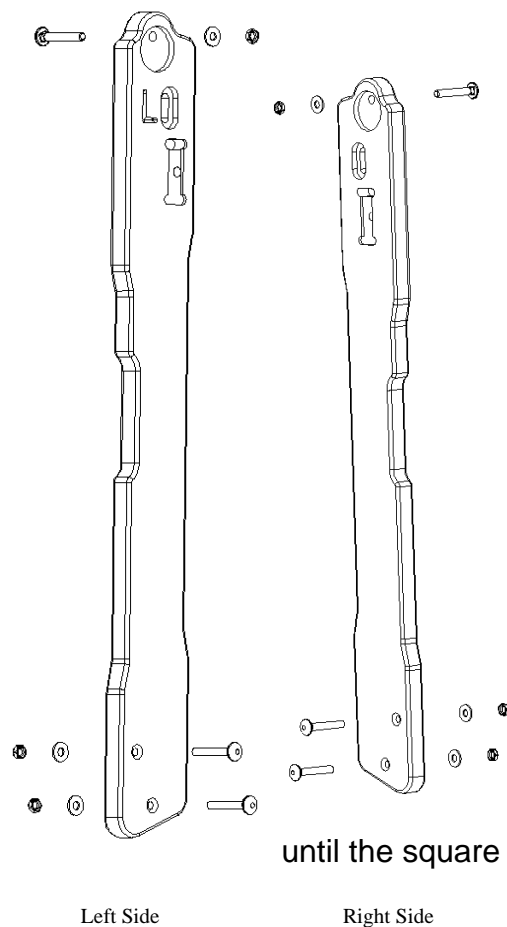

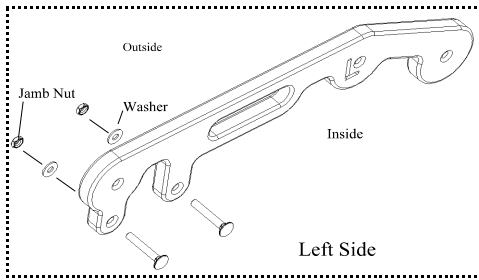

Step 3: Hardware to Pole Mounting Ends

Parts Needed: Right and Left Mounting Ends
 4 - 5/16" x 2" Carriage Bolts
 4 - 1/4" Smaller Flat Washers
 4 - Jamb Nuts

- < Note direction carriage bolt goes through the part.
- < Tighten nuts on carriage bolt to pull the square part of the bolt into the wood until the bolt is seated into the wood part.

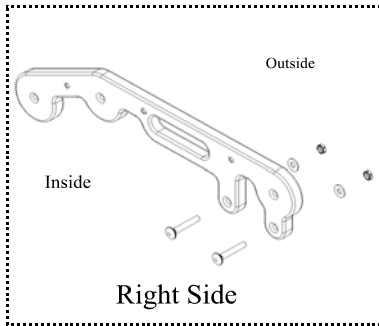

Step 4: Base Feet to Diagonal Stands

Parts Needed: Right and Left Base Feet
 2 - Diagonal Stands (w/ Hardware Installed)
 2 - Wing Nuts
 2 - Nylon Lock Nuts
 4 - 5/16" Large Flat Washers

- < As shown in drawing (right), position carriage bolt ends through holes in base legs.
- < For ease of tightening, thread flat washers and lock nuts onto the bottom carriage bolts first.
- < ****Nylon side of nylon lock nuts faces out when threading onto the Bolt end.****
- < ****Leave all nylon lock nuts loose enough to slide the joint.****
- < Next, thread the washers and wing nuts on the top carriage bolts.

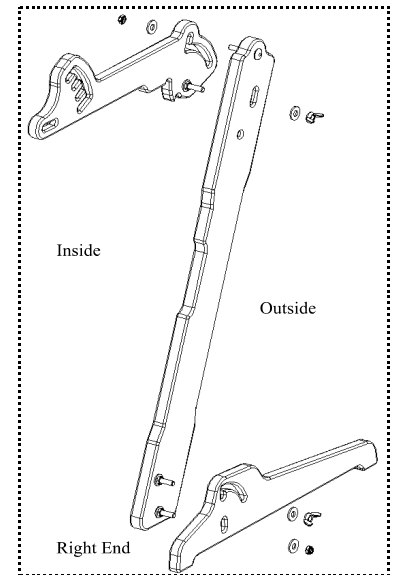

Step 5: Pivot Sections to Diagonal Stands

Parts Needed: Right and Left Pivot Sections (w/ Hardware Installed)
 2 - Wing Nuts
 2 - Nylon Lock Nuts
 4 - 5/16" Large Flat Washers

- < Align the carriage bolts that are already installed on the pivot sections and the diagonal stands through the holes as shown on the pictures (right).
- < Notice that the flat washer and wing nut are threaded onto the end of the lower carriage bolt toward the outside of the frame. The washer and nylon lock nut are loosely threaded onto the upper carriage bolt toward the inside of the frame.

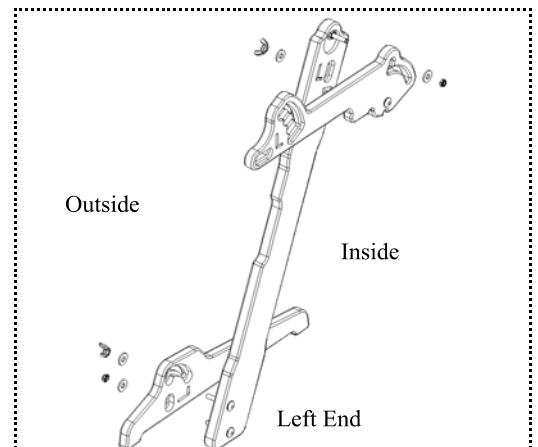

Step 6: Ratchet Wheels to Poles

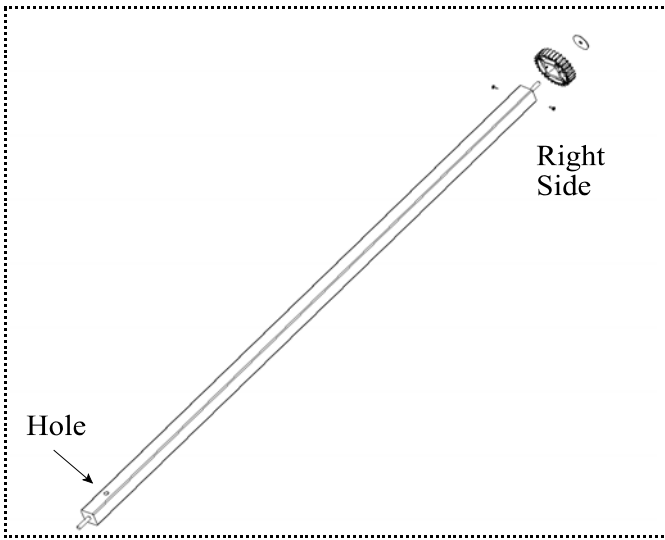

Parts Needed: 3 - Ratchet Wheels

6 - Screws

3 - Quilting Poles

Note: The terms pole and rail are used interchangeably.

- < Identify the three (longer) poles with bolts coming out of both ends, and line them up on the floor so that the holes drilled through the poles are all on the left. Place the ratchet wheels on the end of the pole opposite the hole (see left). Designate which rail will be the front pole.
- < Position the quilting poles through the ratchets as shown in the drawing.
- < Note the direction of the ratchet wheel teeth: Be sure they are going the right direction. (Use the bottom two diagrams on page 4 as a guide. Holding the ratchet stops in proper position, they should fit right in to the wheel when the teeth are facing the correct

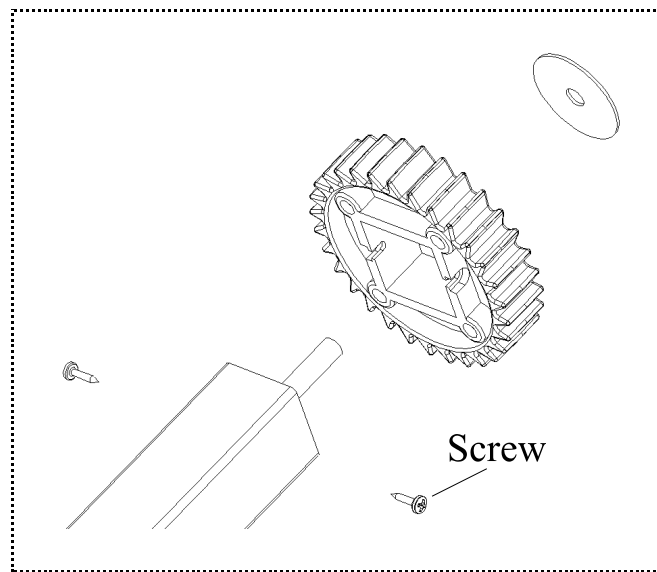

direction).

- < Fasten the wheels to the poles using the small silver grabber screws and a Phillips head screw driver. To properly secure, it will be necessary to screw at a slight angle.
- < It is recommended that you use two screws to fasten

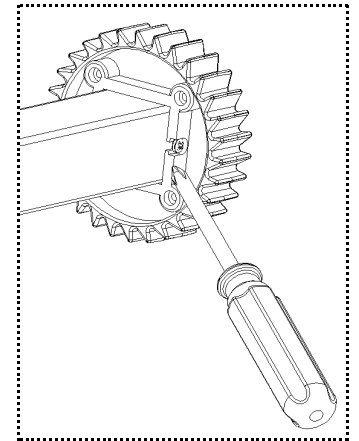

each

wheel.

Step 7: Assembling the frame in different sizes

Parts Available: 3 - Connector Sleeves
 6 - Connecting Bolts
 6 - Cap Nuts
 1 - Smaller Alan Wrench (Black)
 1 - Larger Alan Wrench (Silver)

- < The NMEZ3™ can be set up with the Crib size (56") work area, or Queen size (96") work area.
- < To set up the frame in Crib size, use the three longer rails (that have ratchet wheels) by themselves.
- < To set the frame up in Queen size, combine the two size rails by inserting the longer rail (end

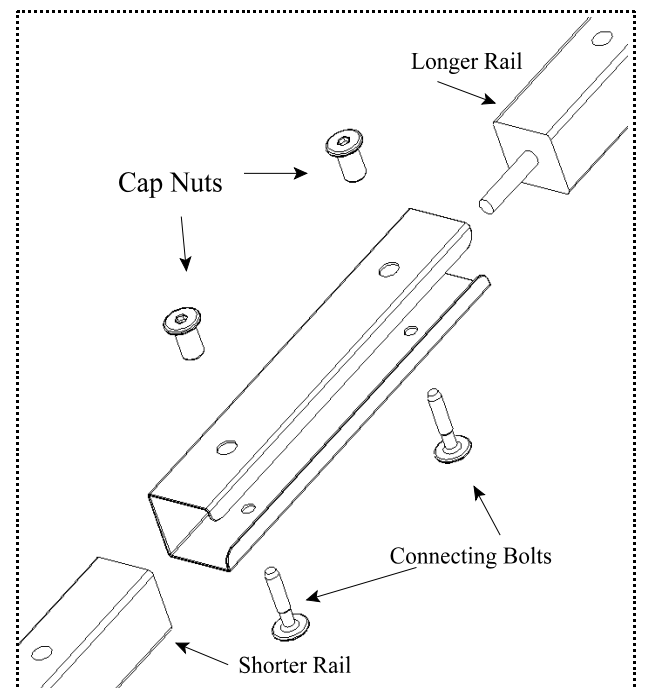

opposite the cog wheel) into the shorter rail (end without the bolt--see right).

< Connect the two rails using the metal connector sleeve. Line up the holes in the sleeve with the holes in the raise. Fasten the sleeve to the rails by putting a connector bolt through the smaller sleeve hole. Then place a cap nut through the larger sleeve hole and thread it onto the connector bolt. Completely tighten using the two Alan wrenches provided. The black one is used with the bolt and the silver one with the cap nut.

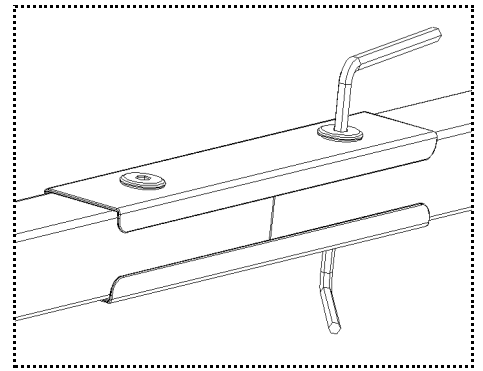

< Repeat this process for the remaining two rails.

Step 8: Ratchet Stops and Poles with Wheels to Mounting Ends

- Parts Needed
- 6 - 1/4" Smaller Flat Washers
 - 6 - Plastic Washers
 - 6 - Nylon Lock Nuts
 - 3 - Ratchet Wheel Stops
 - 3 - 1/4" x 1 1/2"

Hex Head Bolts

< Place a plastic washer on each rail end (see middle right).
 < Position rail bolts (on ratchet wheel end) through the three holes of the Right Pole Mounting End as shown in drawing. Thread the 1/4" Flat Washers and the 5/16" Nylon Lock Nuts onto the ends of these bolts.

< ****All Lock Nuts must be left loose enough that the poles will roll freely.**

< Position the rail bolts on the other end through all the holes of the Left Mounting End. Thread the 1/4" Flat Washers and the 5/16" Nylon Lock Nuts onto the ends of these bolts

< Position the Ratchet Stops as shown (right). Using *fingers--not a tool!--* gently tighten the 1/4" X 1 1/2" Hex Head Bolts through the Stops and into the metal inserts. Only tighten so that the Hex Bolt Head is about

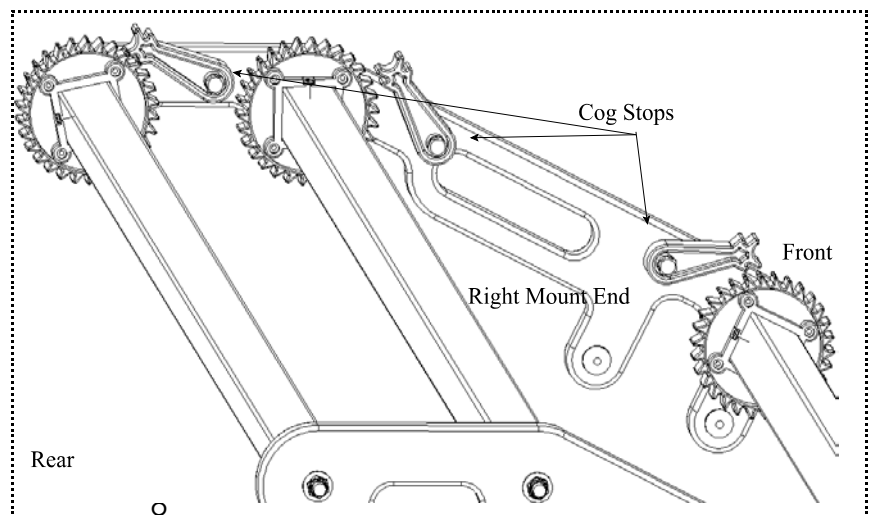
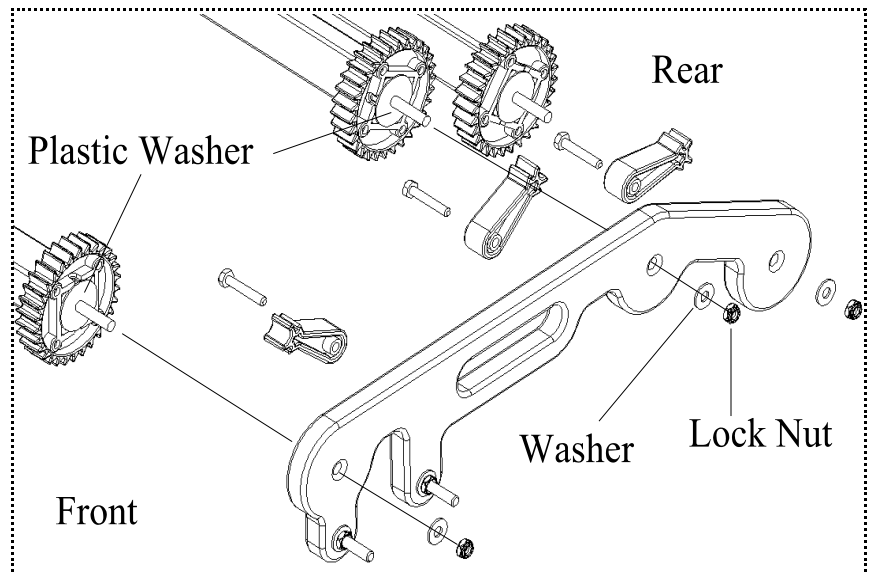
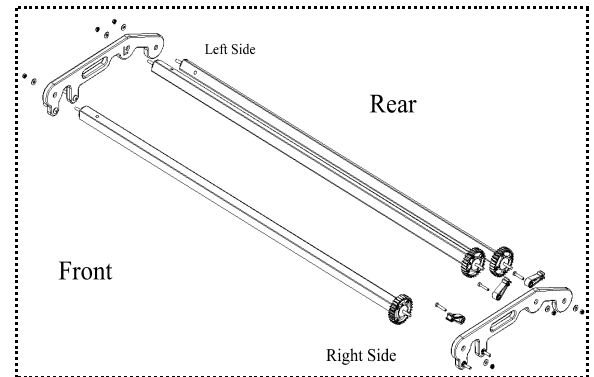

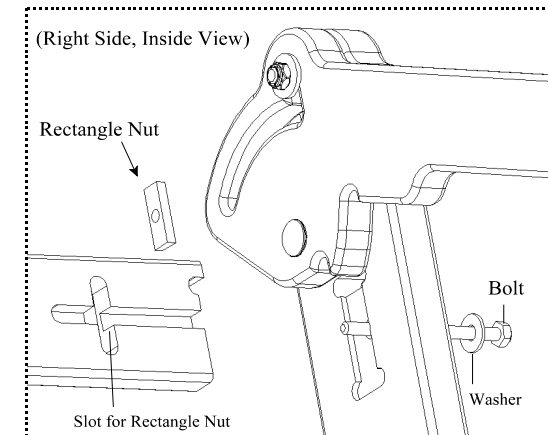
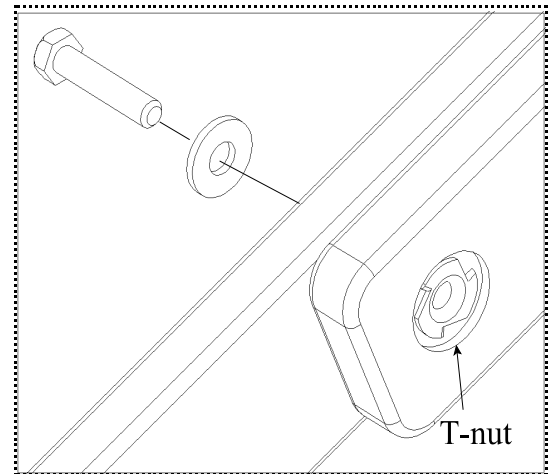
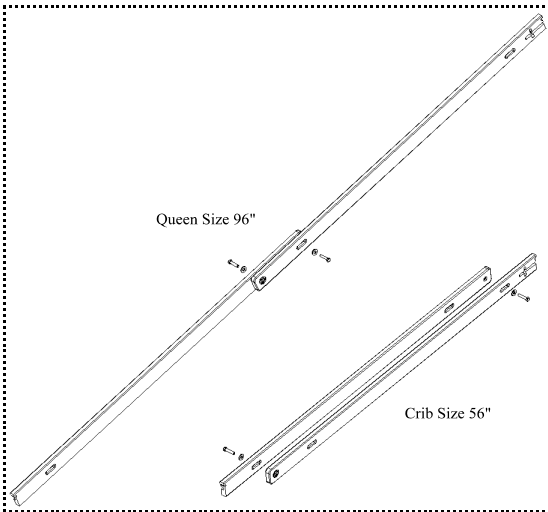

1/4" away from the Stop. *Finger Tighten Only!*

< **Set aside this assembly until Step 10.**

Step 9: Brace Assembly

Parts Needed: 2 - Braces
 2 - 5/16" x 1 1/2" Hex Bolts
 2 - 5/16" Large Flat Washers
 2 - 1/4" x 3 1/2" Hex Bolts
 2 - 1/4" Smaller Flat Washers
 2 - Rectangle Nuts
 2 - Diagonal Stand Assembly

< Match the brace size with the pole size previously assembled. (See top left)

< Connect the two brace pieces together using the 5/16" x 1 1/2" hex bolts and washers as pictured.

< ****Important: Be sure the silver T-nuts (imbedded in the brace) face outside so they are clearly visible. (See middle left).****

< Insert the bolts and washers as pictured. Only finger tighten these bolts at this time.

< Align the keyed end of the brace into the Diagonal Stand as shown in picture (bottom left). Insert 1/4" X 3 1/2" Hex Head Bolt through a 1/4" flat washer (smaller) and into the Diagonal Stand. Place the Rectangle Nut into the slot so the hole lines up with the bolt. Tighten the bolt into the Rectangle Nut until the thbolt is pulled all the way into the slot. This should be a good solid joint. (Repeat for other side).

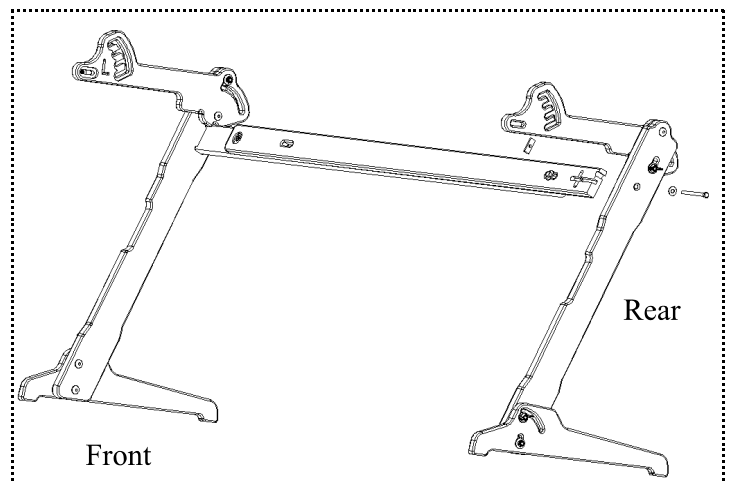

Step 10:

Poles/Ends Assembly to Leg/Stand/Pivot Assembly

Parts Needed: 1 - Pole/End Assembly
 2 - Leg/Stand/Pivot Assembly
 4 - 5/16" Large Flat Washers
 2 - Wing Nuts
 2 - Lock Nuts

- < On the Leg/Stand/Pivot Assembly, slide the braces outward the widest they will go in their current setting.
- < Fasten the Pole/End Assembly to the Leg/Stand/Pivot Assembly by placing the four carriage bolts through Pivot sections on each side as pictured. Do this one side at a time. ****You will need to stretch the last end out slightly to get carriage bolt through it.****
- < With both assemblies together, stand at the front of the frame. Thread a lock nut on the carriage bolt closest to the front, and a wing nut on the one further from the front. (See right). ****Do not overtighten Lock Nuts! The washer must be able to spin freely.**

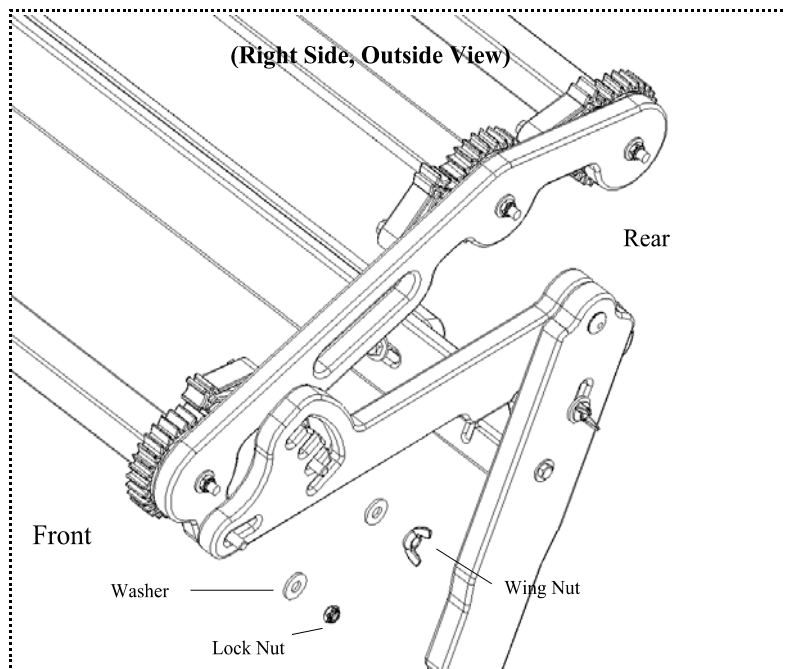

Your Frame is Now Assembled!!

Folding the NM-EZ3™

- < Frame must not be tilted when it is to be folded. (See Tilting the NMEZ3™ in next section.)
- < The folding feature will not affect the quilt in progress.
- < Some practice may be required to fold the quilting frame in 20 seconds.
- < Folded frame is about 6-1/2" wide.
- < **Follow the steps in order, without variation.**

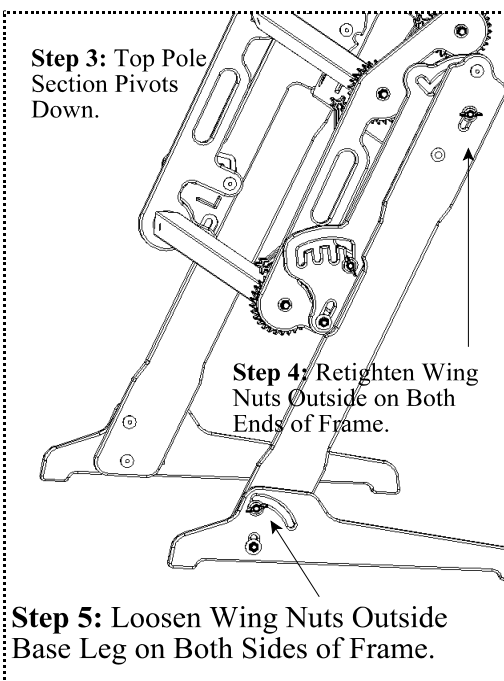

Step 1: Loosen Wing Nuts Outside on Both Sides of Frame.

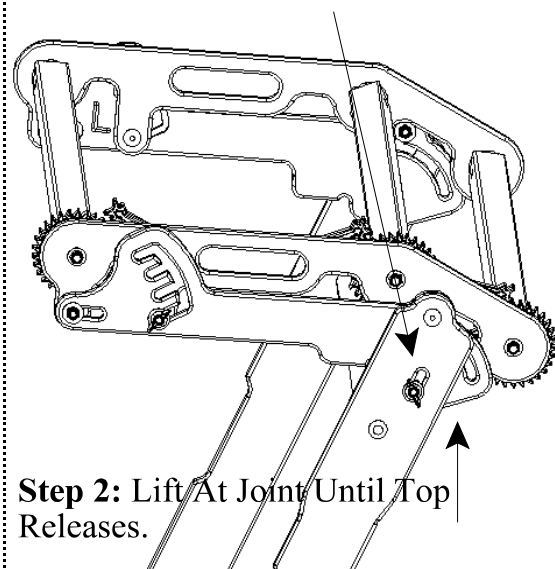

- < **Reverse steps to unfold.**
- < You can use the WingGrip Tool to loosen and tighten your wing nuts!

- Step 6:** Lift Entire Frame From the Brace Until Legs Drop at the Joint.
- Step 7:** Frame Will Rotate Forward and Down.
- Step 8:** Gently Lay Frame Flat

Tilting the *NM-EZ3*TM

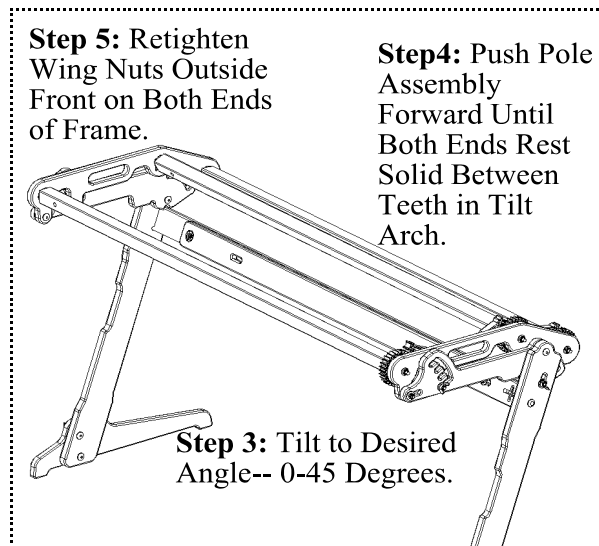
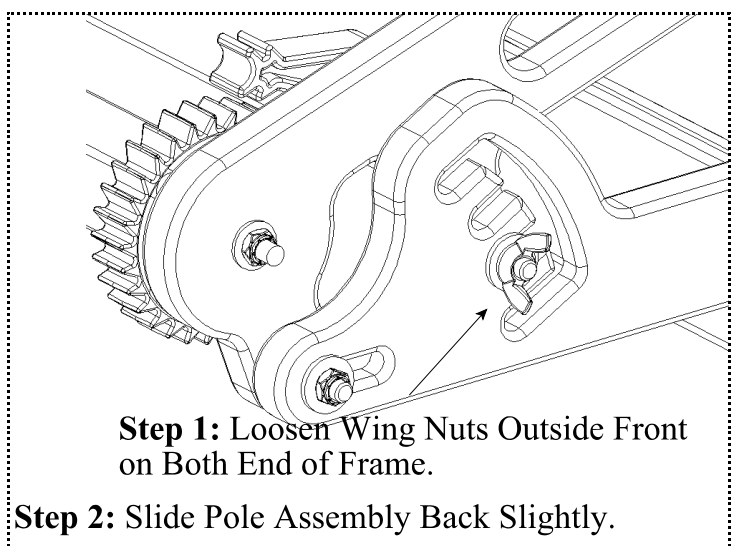

Quilting on the *NM-EZ3*TM

Preparing the Fabric Layers For Installation

<Make sure that each layer of fabric is the correct size and has straight edges and square corners. The short time and small effort that you spend measuring and squaring will result in much time saved later in the quilting process.

<If the lining or backing has a seam running down the middle, then be sure to cut the selvedge off at the seam and press the seam open through its entire length.

<**Bonded batting is strongly recommended.**

Installing the Quilt Fabric Layers

1. Backing Fabric

<The first fabric that will be applied to the quilting frame is the Backing. The Backing is also known as the lining fabric. This piece of fabric will be the under side of the finished quilt. It is recommended that this piece of fabric be larger than the top, on all four sides, especially if your top is a pieced top.

(A pieced top may stretch out and become larger than the backing if you do not make this allowance). The Backing fabric can be one continuous piece of fabric or can be made by sewing fabric together.

2. Piecing the Backing fabric

<Many quilts have back fabrics that are not one continuous piece of fabric and are pieced together using two fabric pieces with a seam down the middle or three fabric pieces with two seams having been sewn. Cut the selvedge off before you piece the back fabric together. The selvedge is woven more tightly than the rest of the fabric and wont

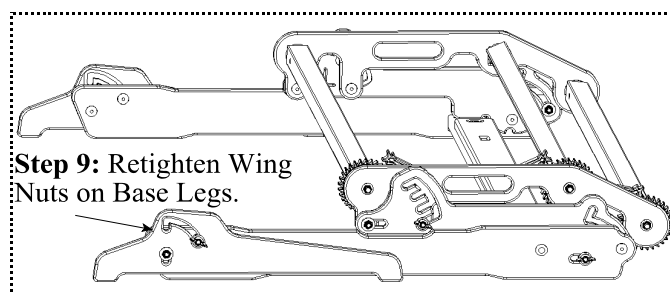

have the same give as the rest of the fabric. This may cause the seam to be too tight. Use a slightly larger, looser machine stitch than normal in sewing/piecing the lengths of the back fabric together. You also can sew your back fabrics together using crosswise piecing.

3. Front Pole- Backing fabric

<Mark the center of Backing Fabric with a pin or pencil mark.

<Tack the center mark to the center of the Front Pole. (The Backing Fabric is put on with the wrong side of the Fabric up and visible.)

<Lay the Fabric naturally and evenly along the straight edge of the Pole. **Do not stretch the Fabric from side to side.** Tack the corners of the Fabric to the Pole. <Add a few more Tacks to hold the material on the Pole

4. Middle Pole- Opposite end of Backing Fabric

<Tack the other end of the Backing Fabric to the Middle Quilting Pole, centering with the mark as directed on the Front Pole.

<Tack the center mark to the center of the Middle Pole. Lay the Fabric naturally and evenly along the straight edge of the Middle Pole. **Do not stretch the Fabric.** Tack the corners of the fabric to the Pole.

<Make sure that the amount of wood showing at the edges of the Fabric to the End Boards is the same on all Poles.

<Securely tack the Backing Fabric along the entire edge of the Middle Pole, using plenty of Tacks.

<Roll the material onto the Middle Pole, making a smooth roll. Be sure that no wrinkles are present.

<Smooth the Quilt from the center to the outside edges of the Pole as it is being rolled. At this point do not roll the Fabric tightly, just nicely smooth and even.

<Roll until there is very little slack between the two Poles.

<***Note* Fabrics should never be tight. For best results, use as little tension as possible without letting the Quilt sag.**

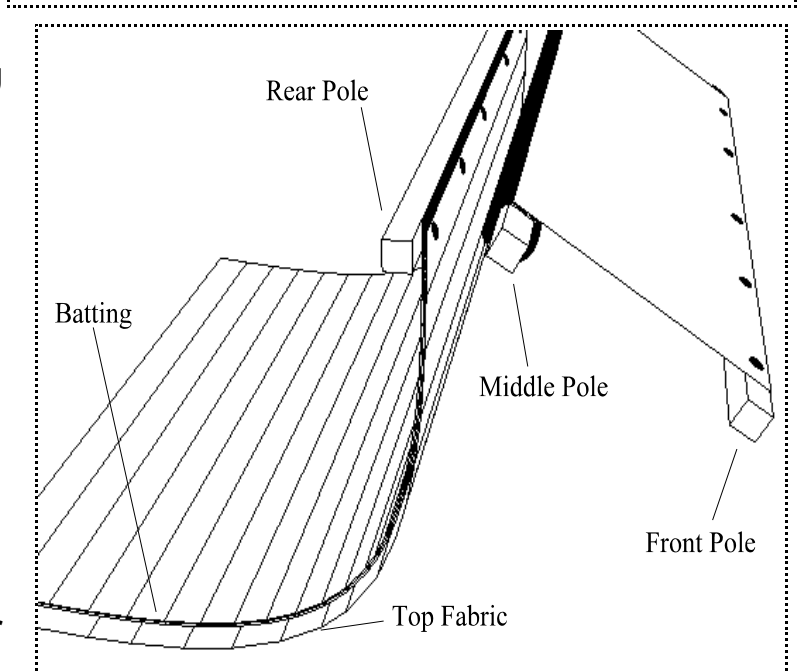
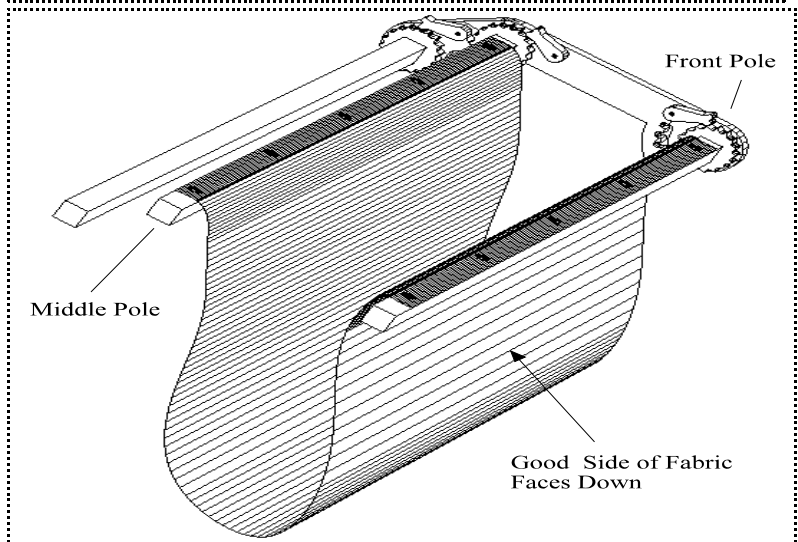
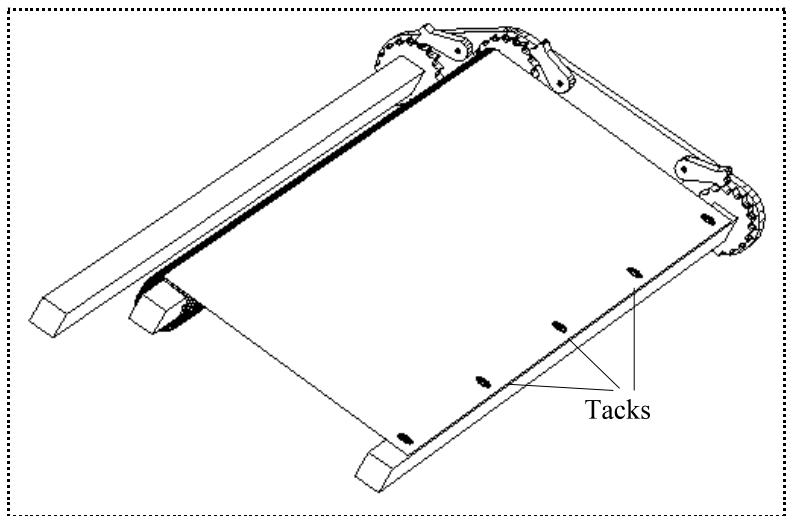

5. Batting and Quilt Top

<Lay the Quilt Top face down on the floor and line your batting directly over it. Mark the center of the

Top.

< Line up the edge of the Quilt Top/Batting to the inside rear pole as shown.

<Tack the center the Top/Batting to the center of the rear pole. Tack the corners. Make sure that the Quilt Top is centered with the Backing already installed.

<Roll the Top/Batting onto the rear pole by rolling the rail away from the front of the frame. Make sure it rolls smoothly.

<When you reach the end of the fabric, pull the loose end of the Top/Batting over the backing and line it up on the front rail.

<Completely tack the Batting and Quilt Top moving from the center out to each corner.

<**Remember to smoothly and evenly lay the Quilt Top to the Front Pole *without stretching* from corner to corner during the tacking process.**

<On the rear pole, measure the wood from quilt edge to End Board. This measurement should be equal to the Quilt Top edge to End Board measurement of the Front Pole.

<Adjust the tension to the Backing Fabric and Batting and Quilt Top Fabrics until you get the desired tensions. **DO NOT OVER TIGHTEN!**

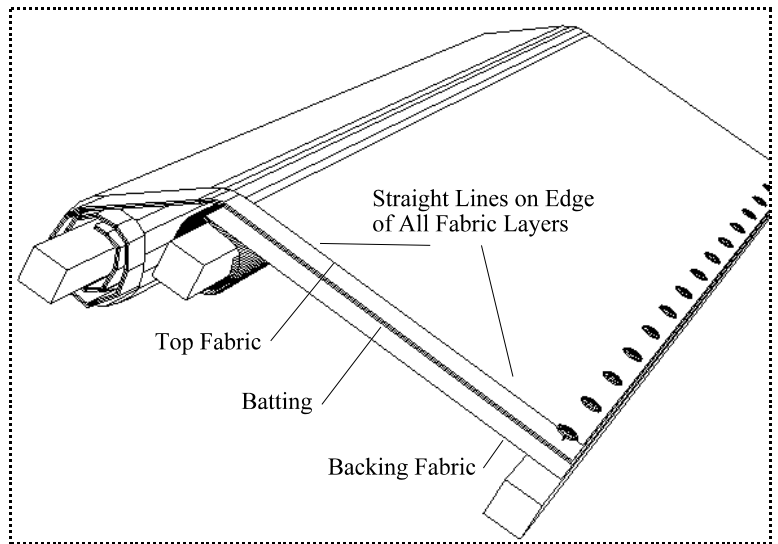

TROUBLE SHOOTING

Problem: *Fabric sags on one side or in middle.*

Solution: *Fabric may not be cut evenly straight or the grain of the cloth may not be square. Take it off and square it up or pull (gently) to square.*

Problem: *Sides of quilt have a concave edge.*

Solution: *The fabric was stretched along the pole. Take the fabric off and let it relax until it is not misshapen and then re-install, without stretching it along the edge.*

Problem: *Batting tears or separates during the tightening of the ratchet wheels.*

Solution: *The Batting was stretched and stressed. The Batting should be longer than the Quilt that you are making and there should be no tension applied to it. Remember to use a few extra inches of Batting and let it sag down between the two rear poles. This will stop the Batting from pulling. You may unroll the rear pole and fix the Batting at any time during the quilting process.*

Problem: *Poles are bowing in.*

Solution: *The causes may be: 1. Seam down the center of the Fabrics may be sewn too tightly and is not giving with the rest of the Fabric. If the Seam is the problem the Quilt may be tatched sideways, 2. Fabric is not cut evenly. 3. Too much tension has been applied. 4. Fabric has been stretched along the Poles instead of naturally attached.*

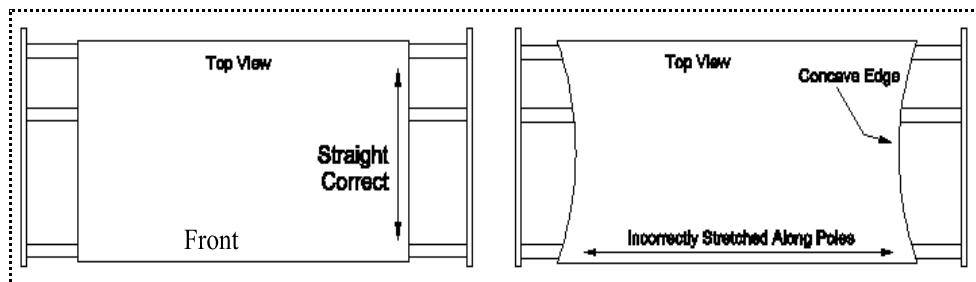

Problem: *Fabric pulls/tears out at the Thumbtacks when tension is applied.*

Solution: *Seat the Tack all the way in. The Head of the Tack, not the post of the Tack, should hold the Fabric. Use a Tack Hammer to seat the Tacks if your hand is not strong enough.*

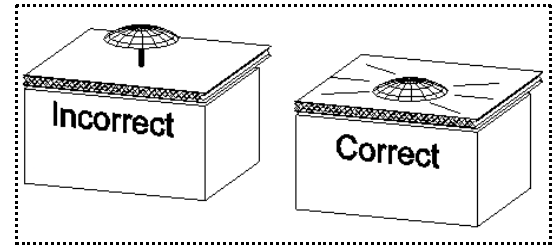

Problem: *Poles squeak as they roll or they do not roll freely.*

Solution: *The Nylon Lock Nuts are too tight. Loosen them with a 1/2" wrench about 1/2" to a full turn. If the Quilting Frame still squeaks or is difficult to roll make sure that the frame is in good square alignment and/or rub some Paraffin or Candle Wax on the Bolts in the ends of the Poles.*

Helps for Tied Quilts:

Before installing the Quilt onto the Frame, mark both the Quilt Top and Backing in a similar increments along the two side edges. (The sides that are not tacked onto the Poles.) While rolling the Quilt during the tying process watch the marks. This will help you to keep an equal tension on the Top and Backing Fabrics so you won't over tighten one or the other of your Fabrics. When rolling into a new area of tying, allow your last row of ties to remain in the new area of tying. Also, tie your knots tight. **Do Not over roll your last row of ties over the turn in the Pole.**

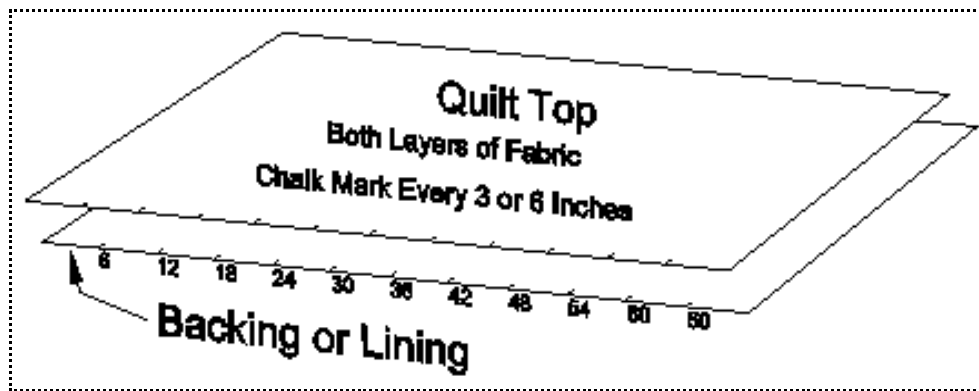

Making and Using Cloth Leaders

Use of cloth leaders

<**This is only a suggestion for making one kind of cloth leaders.** There are many ways and ideas for making cloth leaders. Don't hesitate about trying your own ideas. Just *remember that the widest strip of fabric should be applied to the rear pole. This allows the whole quilt to come up into the area of quilting without stopping and adjusting the quilt top to the second pole in order to finish it.* <*The best cloth selection for making cloth leaders is unbleached muslin or mattress ticking. However, the ticking is a much more expensive selection.*

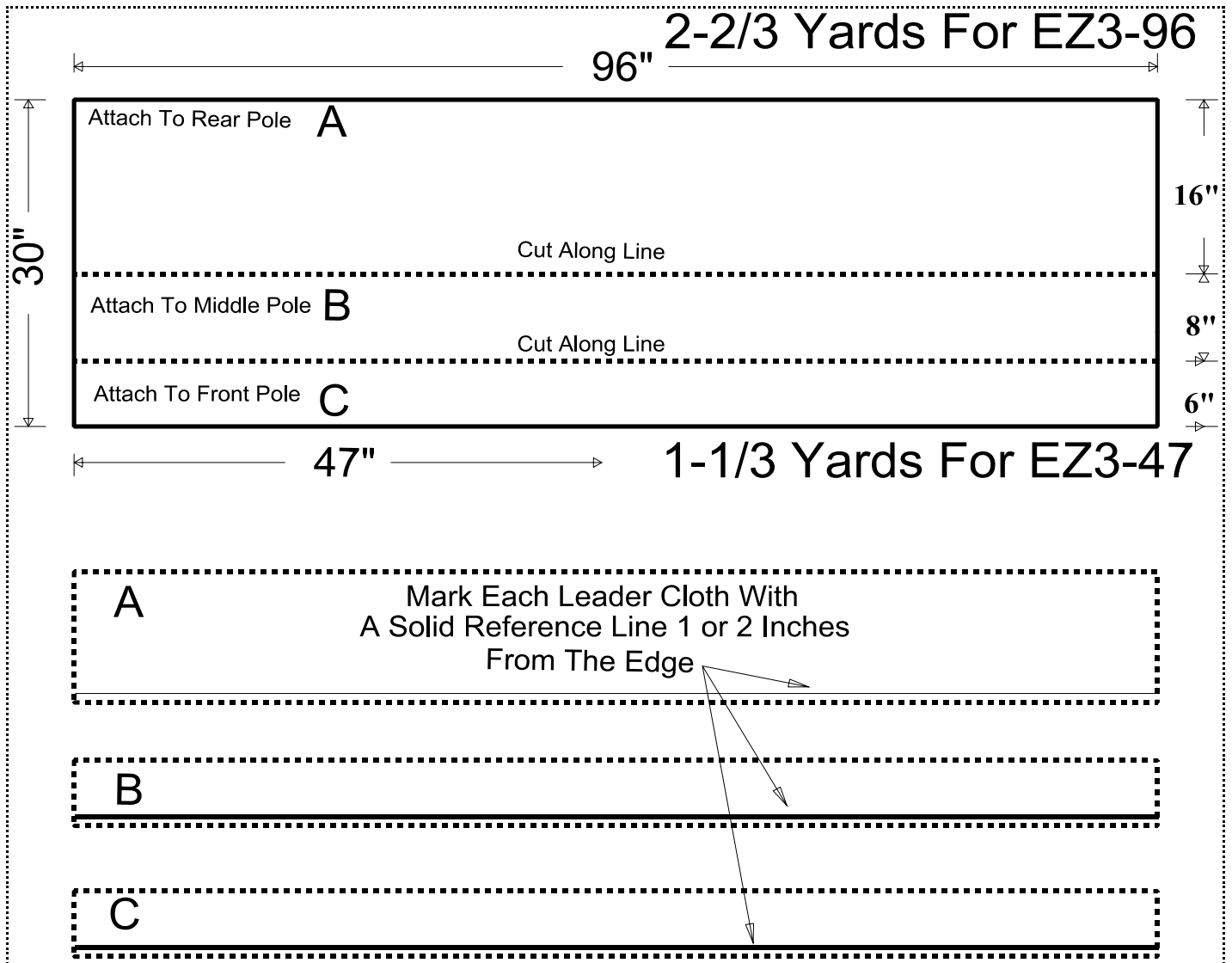

<Purchase: 2-2/3 Yards of Fabric (Mattress Ticking or Canvas work best).

<**Step 1.** Cut the fabric as shown in illustration above.

<**Step 2.** Finish the cut edges of the leaders with either a serge stitch or with a very straight 1/2" hem allowance. **Press the leader cloth with a warm iron.**

<**Step 3.** Draw straight, dark, solid line 1" from one edge of each of the leader cloths.

<**Step 4.** Thumb tack the cloth leaders to the poles as shown on illustration below.

<**Step 5.** Pin or baste your quilt fabrics to the cloth leaders. Use the dark, straight line that you marked on your leaders in Step 2 to align your quilt fabrics with.

<**Step 6.** Roll the Cloth Leaders and Quilt Fabrics up on Poles.

<**Step 7.** You are quilting.

now ready to begin

